

机械制图

CAD

课程思政教学设计说课

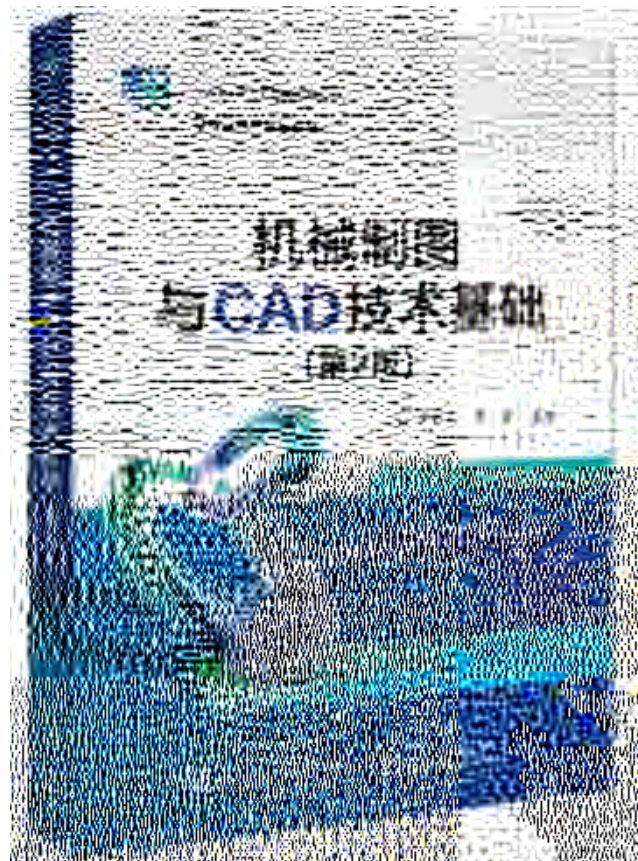



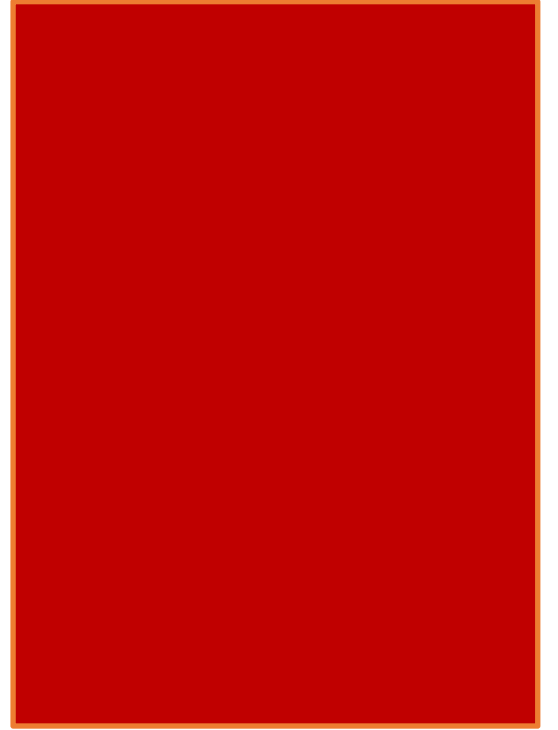





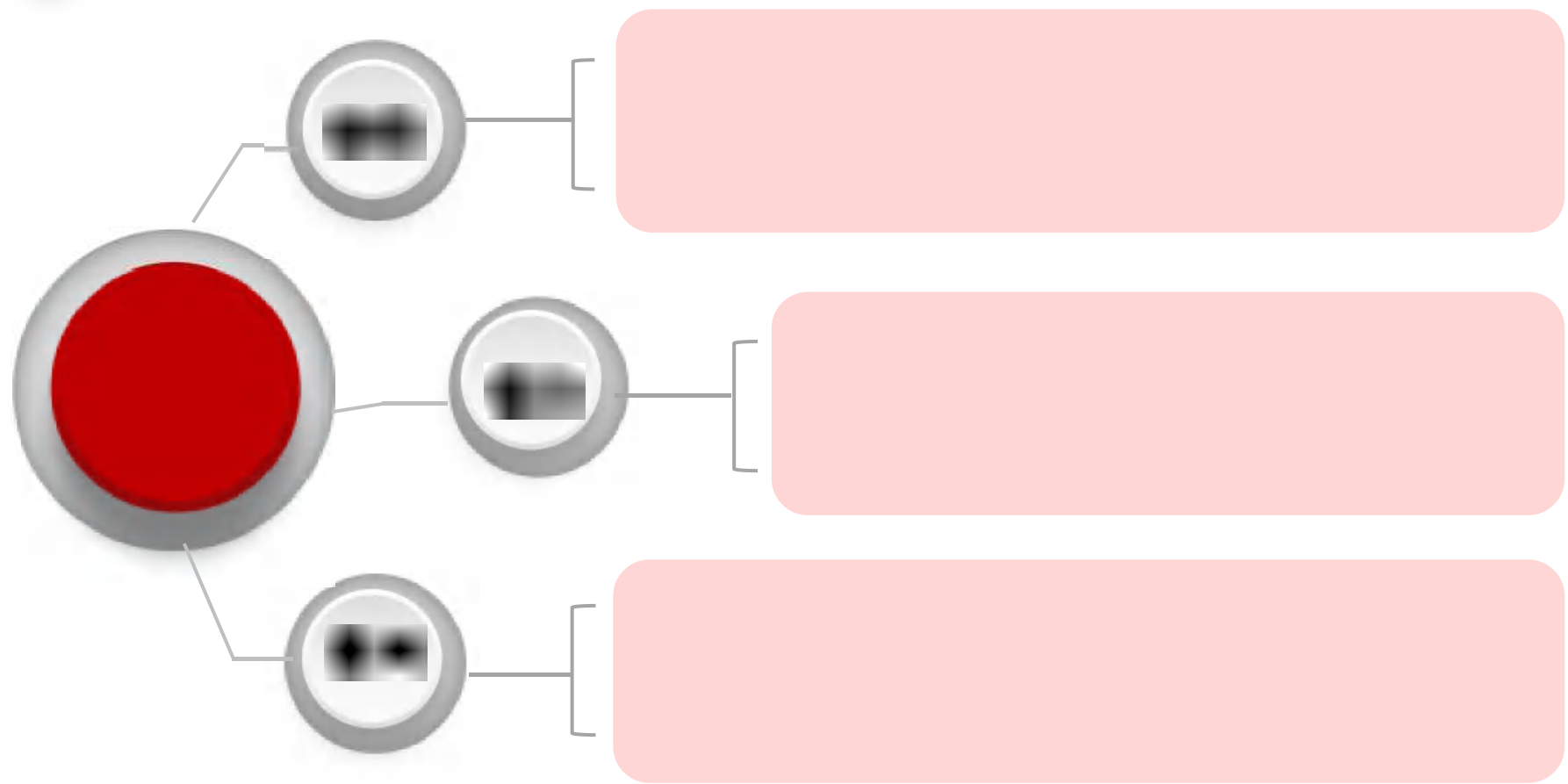

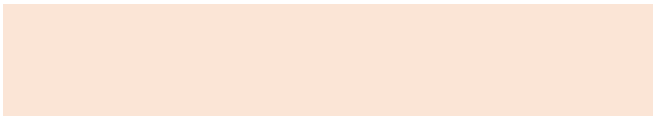
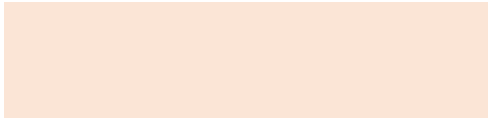



评价方式	评价类型	评价载体	评价指标	权重
混合式多元化评价体系	过程评价	课前线上	自主学习视频、资源时长	10%
			讨论区互动、发帖、评论	10%
			在线作业	15%
		课中线下	考勤	5%
			积极发言	5%
			参与讨论	10%
		课后线上	小组汇报	15%
			单元测验	10%
			小组作业	20%
	增值评价	图纸作品	思想素养	16%
			行为素养	13%
		技能比赛	专业素养	45%
			社交素养	12%
			心理素养	14%
结果评价	职业考证	100%		
	期末考试	20%		
综合评价	日常评价	20%		
	综合素质评价	30%		
	同行评价	20%		
		长周期评价	30%	

内外螺纹的画法评价体系表

一、内外螺纹的绘制任务

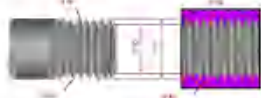

二、评价打分表

评价方式	评价类型	评价载体	评价指标	权重	备注
混合式多元化评价体系	过程评价	课前线上	内外螺纹的绘制视频学习时长	10	
			讨论区互动、发帖、评论	10	
			在线测试	15	
		课中线下	考勤	5	
			螺纹的主要画法发言	5	
			内外螺纹的画法讨论	10	
		课后线上	小组汇报	15	
			单元测验	10	
			螺纹要素及画法线上测试	20	
	增值评价	图纸作品	思想素养(螺纹要素分析正确)	16	
			行为素养(圆角倒圆准确、思路清晰)	13	
		技能比赛	专业素养(螺纹综合绘制正确)	45	
			社交素养	12	
			心理素养	14	
结果评价	期末考试	100			
	日常评价	20			
综合评价	综合素质评价	30			
	同行评价	20			
	长周期评价	30			





现在开始讲课

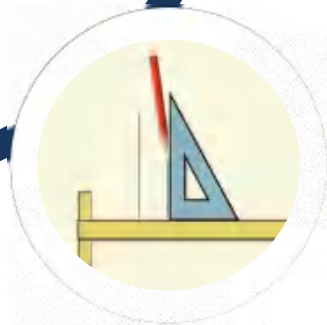
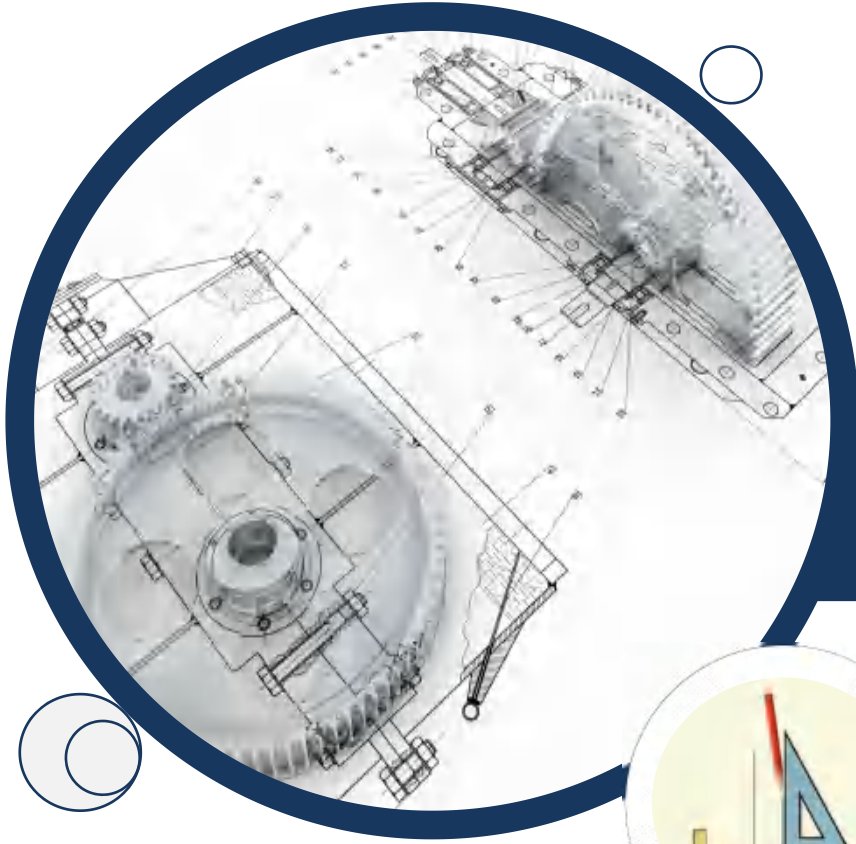

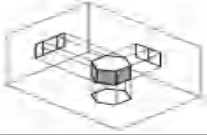

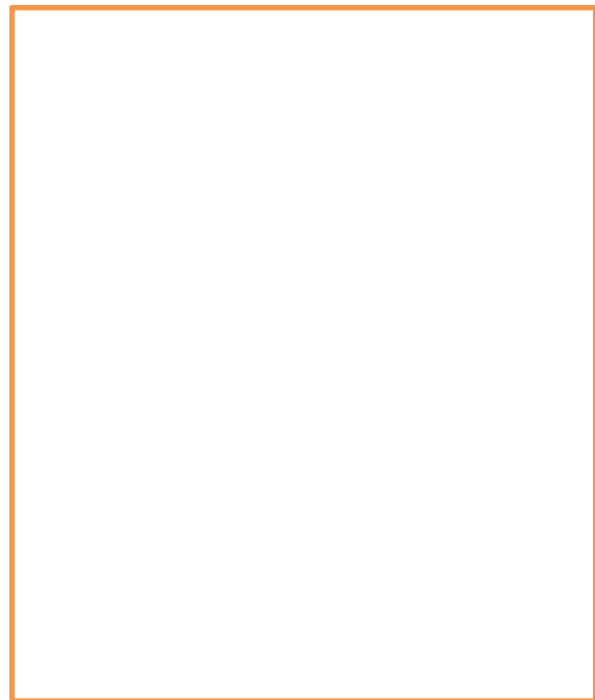

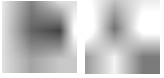
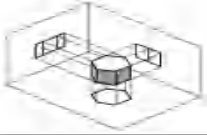

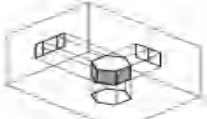

-
-
-

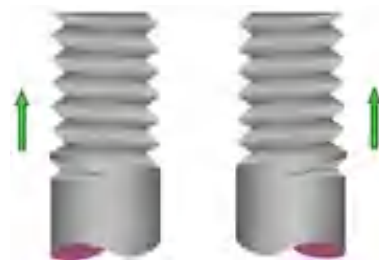
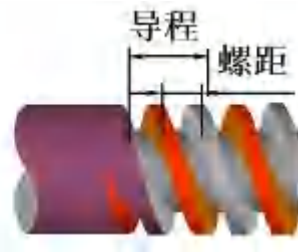
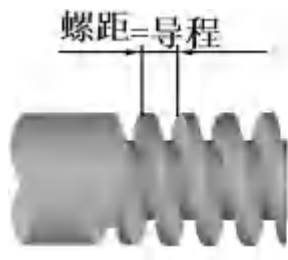
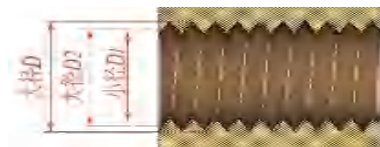

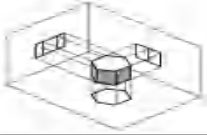

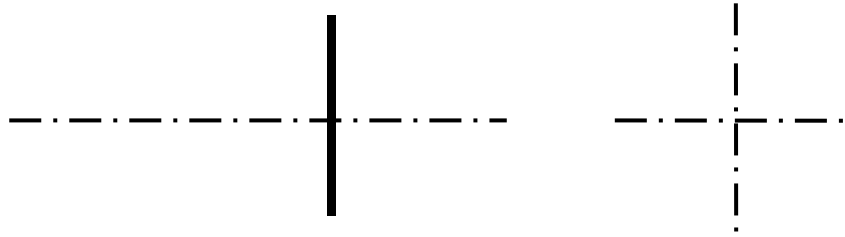
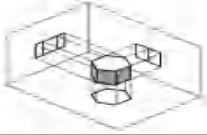

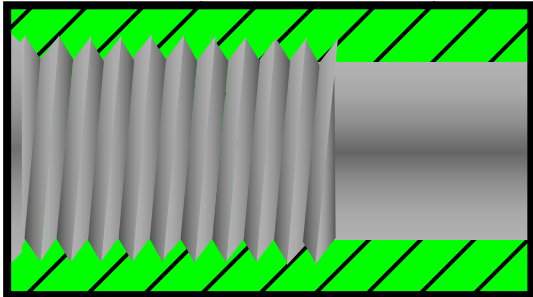
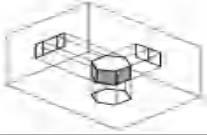

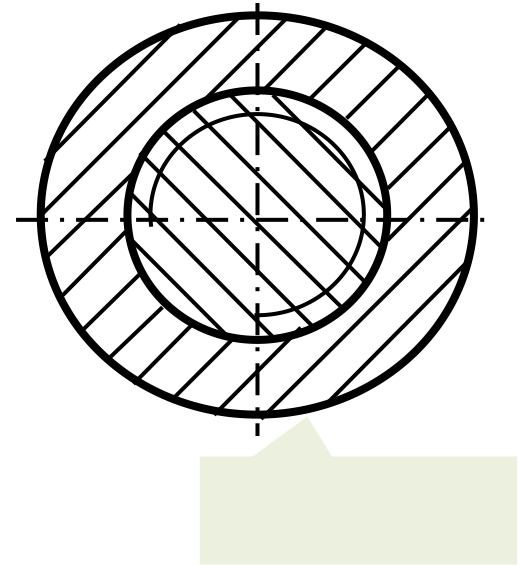
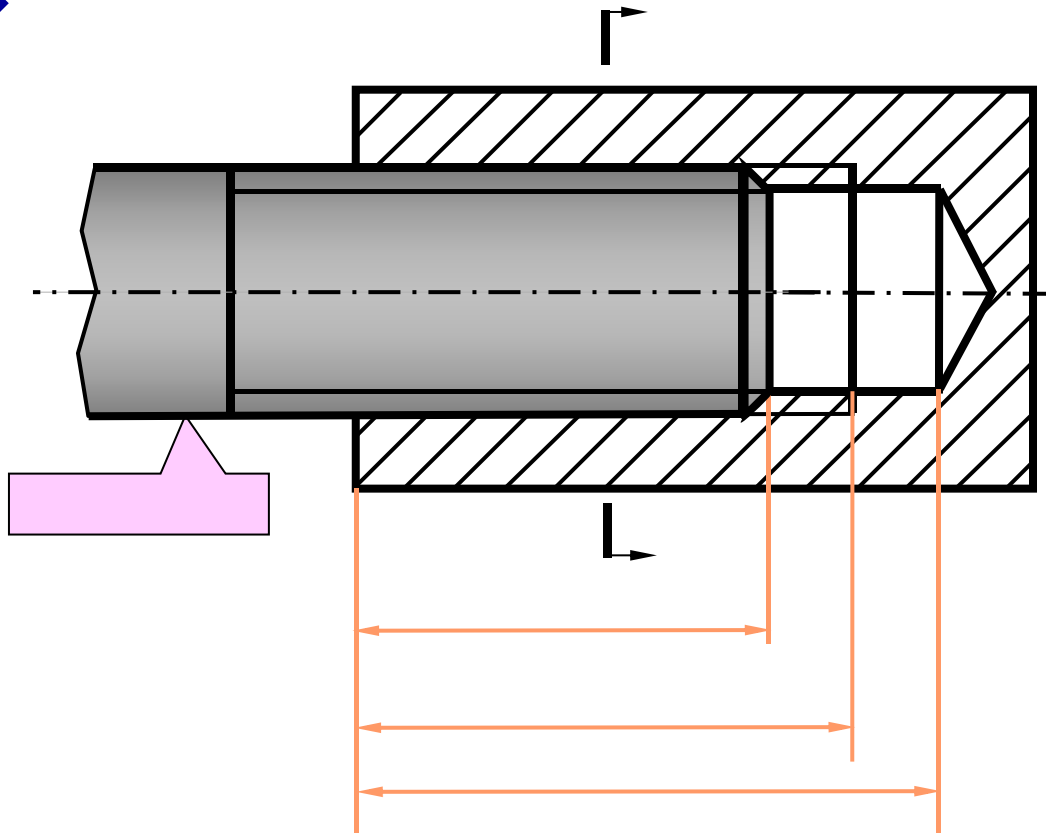
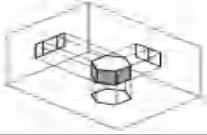

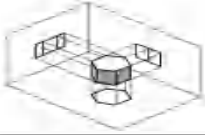

- [Redacted]

- [Redacted]

- [Redacted]

- 严谨、细致、规范、精益求精

